

Collection Moll
12721010000 Towel ring

PRODUCT

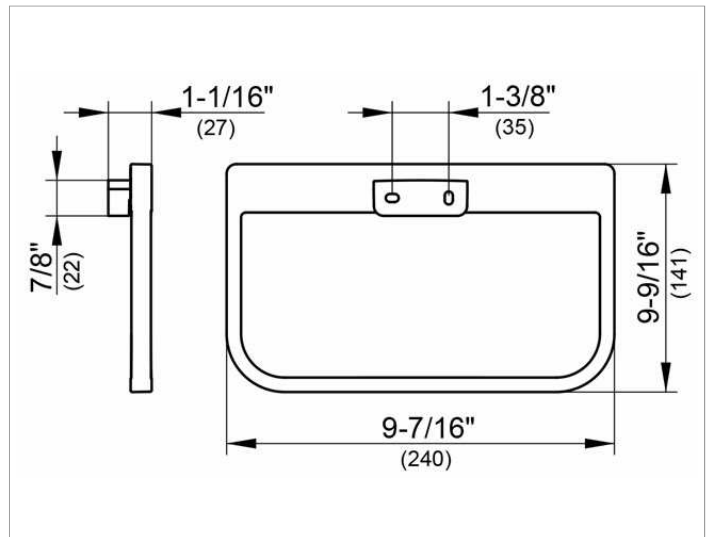

DRAWING



SURFACE

chrome-plated

SPECIFICATIONS

KEUCO COLLECTION MOLL towel ring 1272010000
 Chrome-plated towel ring in an esthetic design with slightly rounded edges, closed form, rectangular, bottom edges are rounded, towel ring swivels, anti-static, easy to clean
 Width 240 mm, Height 141 mm
 The towel ring is fitted with two hidden fixing points incl. corrosion-free mounting material

Warranty: KEUCO products are covered by a 5-year manufacturer's warranty, in effect from the date of purchase. During this time, proven product defects will be remedied free of charge. Warranty claims must be filed in writing, including a detailed description of the defect immediately after a defect has occurred. For a copy of our detailed product warranty policy, please contact us at office-usa@keuco.com.
Installation: KEUCO products must be installed by a qualified professional in accordance with the respective installation guidelines and any applicable federal / local building codes and regulations.