

BILL OF MATERIAL (CURRENT LEVEL)				
ITEM	PT/ASSY	DESCRIPTION	TYPE	QTY.
1	403X-1	ANGLE VALVE, CROSS CONTEMP.	ASSEMBLY	1
2	432	BULLNOSE TUBE 3/8 X 20	PART	1
3	441	FLANGE FOR 5/8 OD	PART	1

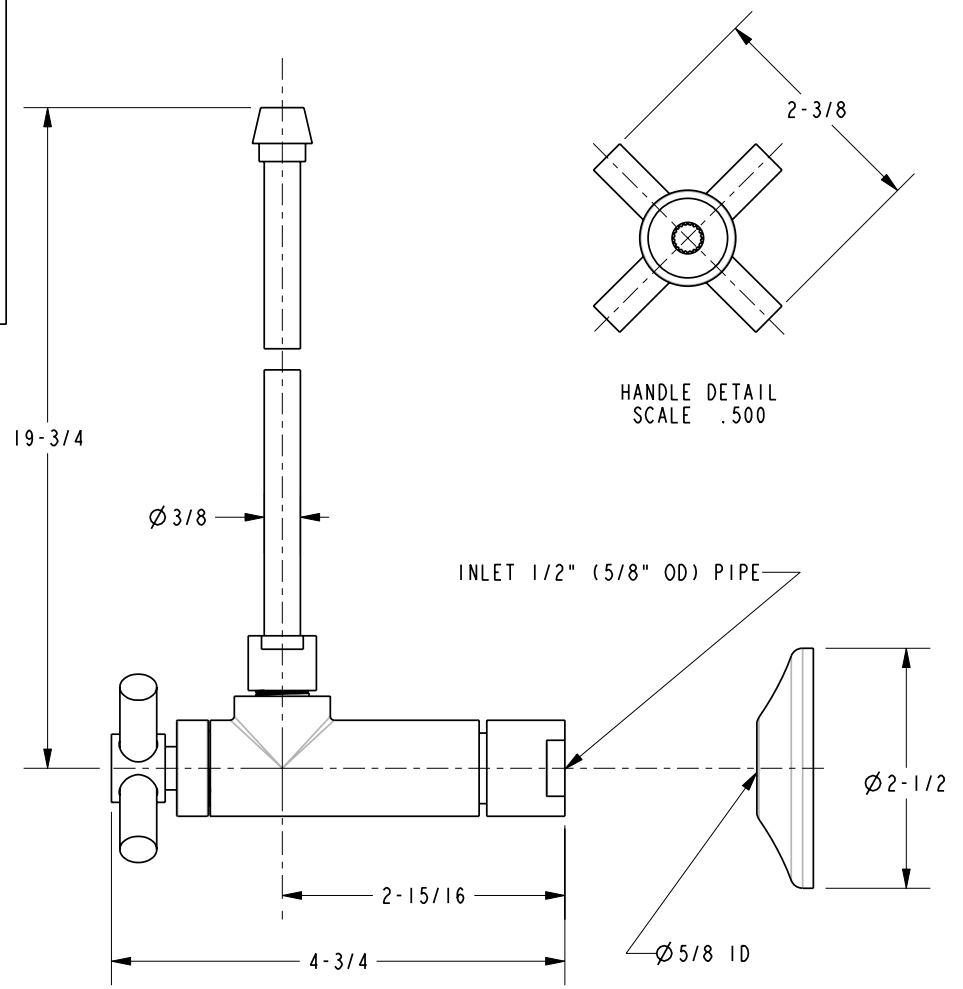
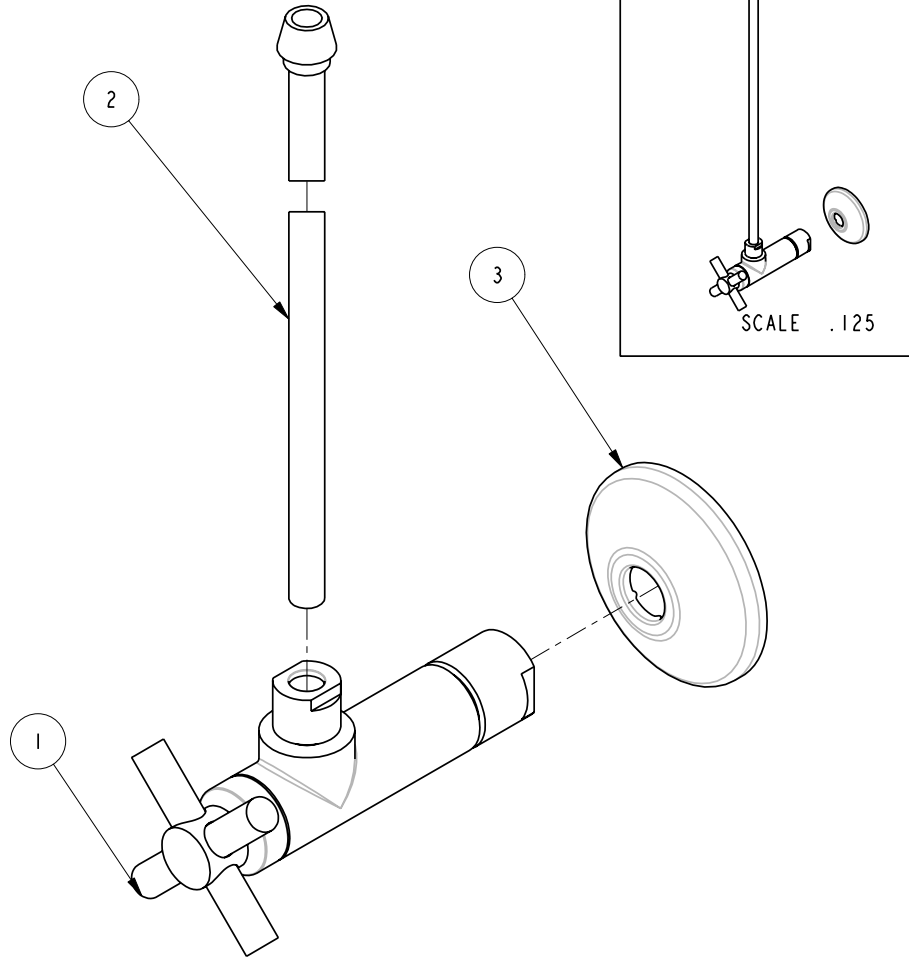

COPYRIGHT 2005 BRASSTECH, INC. THESE DRAWINGS AND THE DESIGNS DEPICTED HEREIN ARE THE PROPRIETARY PROPERTY OF BRASSTECH. ANY USE OR REPRODUCTION IS SUBJECT TO THE EXPRESS APPROVAL OF BRASSTECH. UNAUTHORIZED USE IS STRICTLY PROHIBITED. ALL RIGHTS RESERVED.

BRASSTECH INCORPORATED	2001 E. CARNEGIE AVE. SANTA ANA, CA 92705 (949) 417-5207	SUPPLY KIT 1/2CMP 3/8X20" BULLNOSE RISER	ASSY. NO. 493X-1		-	-	-
			SCALE .500	REF. -	SHEET 1 OF 1	REV	REV DESC