



-  LOCATION FOR VHB TAPE
-  APPLY PLAMER MIRROR MASTIC
-  APPLY LOCTITE 680.

BILL OF MATERIAL (CURRENT LEVEL)				
ITEM	PT/ASSY	DESCRIPTION	TYPE	QTY.
1	91477	ADHESIVE BACKED BUMPER	PART	2
2	C0642	MIRROR GLASS	PART	1
3	F642-CB	MIRROR TIEROD 24"	ASSEMBLY	1
4	MTM-003	MIRROR VERTICAL CHANNEL	PART	2
5	MTM-002	MOUNTING KIT	ASSEMBLY	1
6	92398	SCRW,M5 X .8 X 8 PHIL PAN HD Zn PLATED (MMC# 92005A318)	PART	4
7	F64X-SC	SIDE ARM ASSEMBLY	ASSEMBLY	1

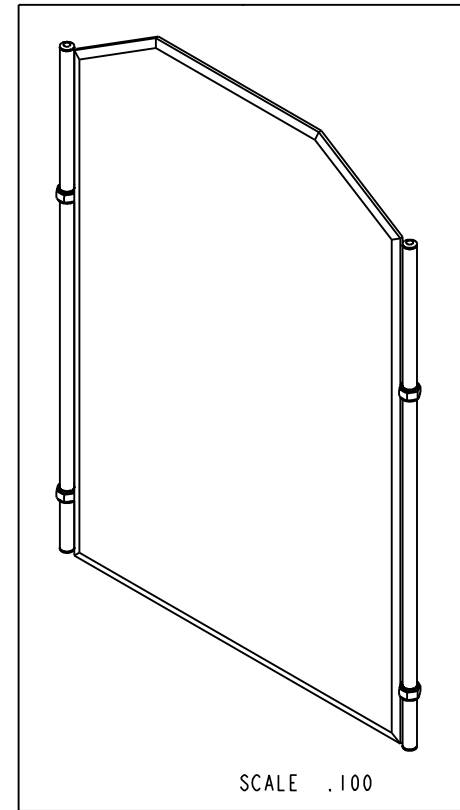
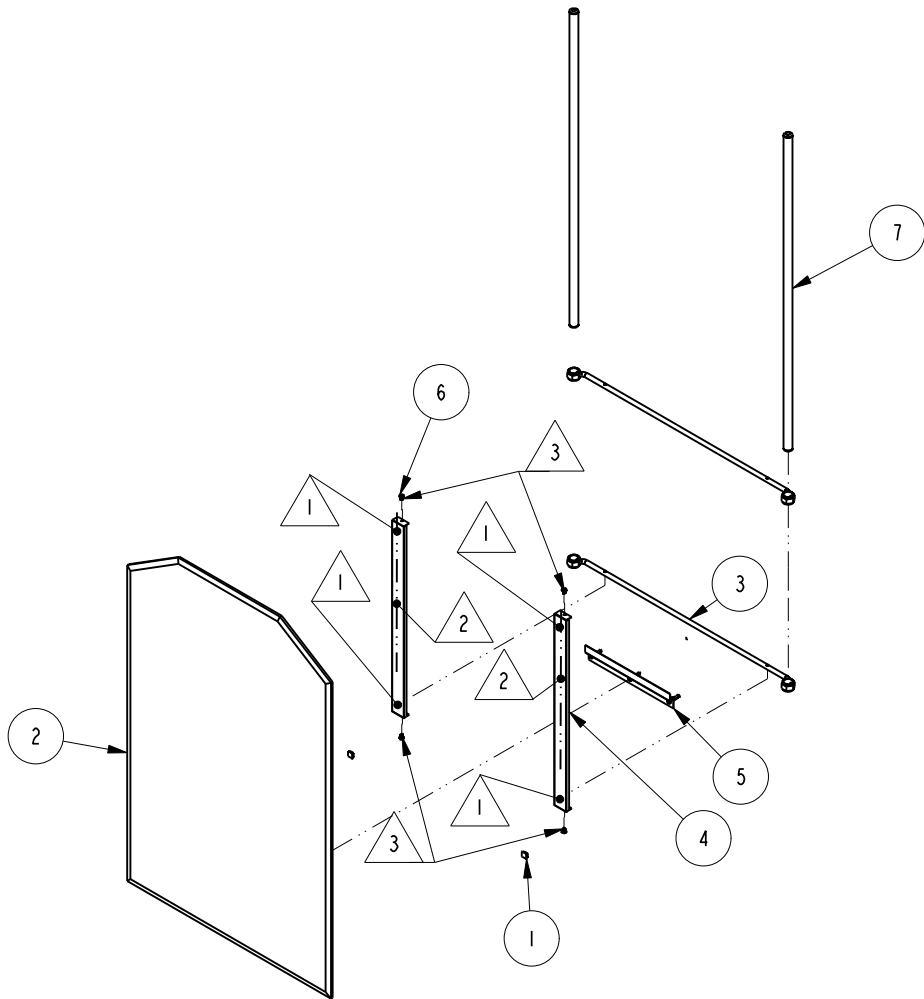

COPYRIGHT 2005 GINGER. THESE DRAWINGS AND THE DESIGNS DEPICTED HEREIN ARE THE PROPRIETARY PROPERTY OF GINGER. ANY USE OR REPRODUCTION IS SUBJECT TO THE EXPRESS APPROVAL OF GINGER. UNAUTHORIZED USE IS STRICTLY PROHIBITED. ALL RIGHTS RESERVED.

GINGER

2001 E. CARNEGIE AVE.
SANTA ANNA CA 92705
(949) 417-5207

EMPIRE LARGE FRAMED BEVELED MIRROR

ASSY. NO.		B	EN-2270	09/03/12
642		A	EN-1460	02/09/10
SCALE .063	REF.	SHEET 1 OF 3	REV	REV DESC
				DATE

SPECIFICATION DWG

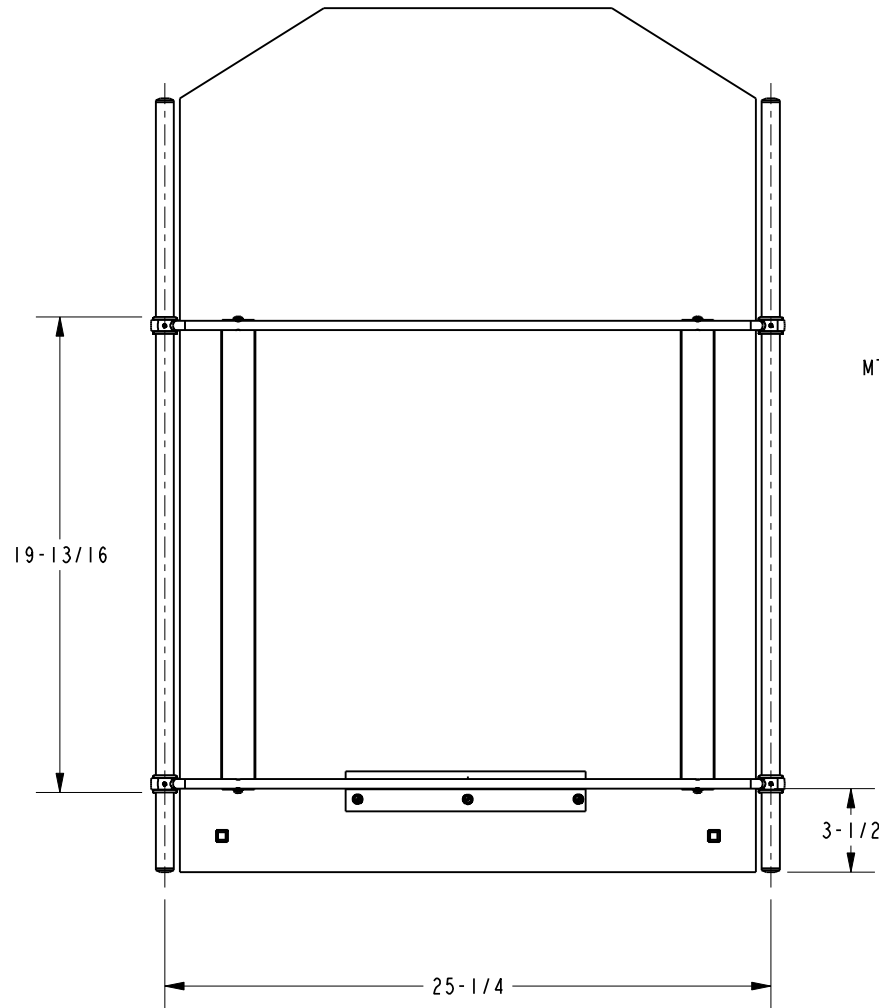

MTM-009 SOLD SEPARATELY

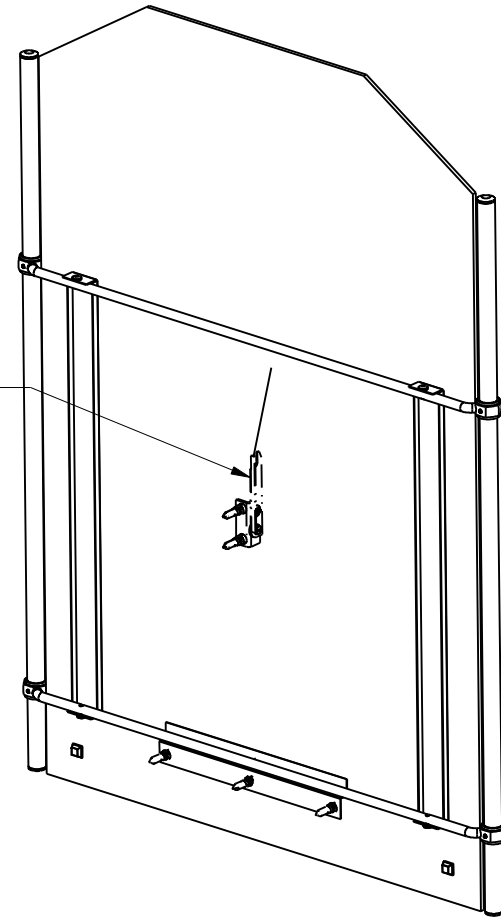

DIMENSIONS ARE IN INCHES AND AN APPROXIMATION OF A TYPICAL INSTALLATION

COPYRIGHT 2005 GINGER. THESE DRAWINGS AND THE DESIGNS DEPICTED HEREIN ARE THE PROPRIETARY PROPERTY OF GINGER. ANY USE OR REPRODUCTION IS SUBJECT TO THE EXPRESS APPROVAL OF GINGER. UNAUTHORIZED USE IS STRICTLY PROHIBITED. ALL RIGHTS RESERVED.

GINGER		2001 CARNEGIE AVE. SANTA ANA CA 92705 (949) 417-5207	
DWG NO.	642	REV	B
SCALE	.125	REF.	SHEET 2 OF 3

SPECIFICATION DWG

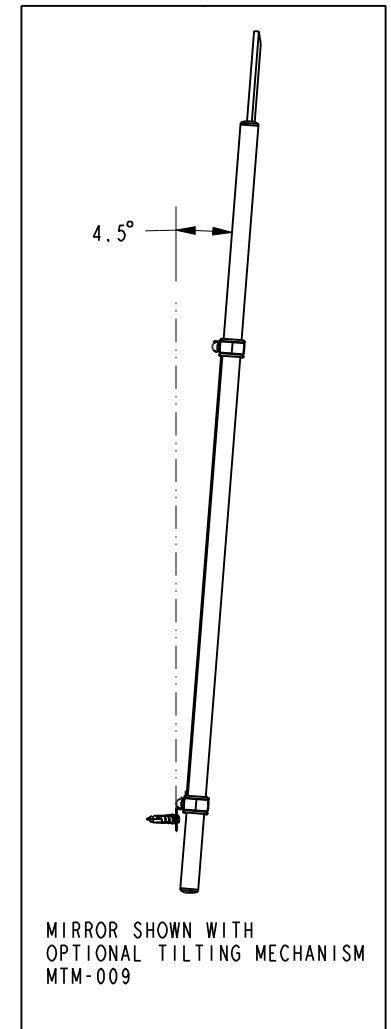
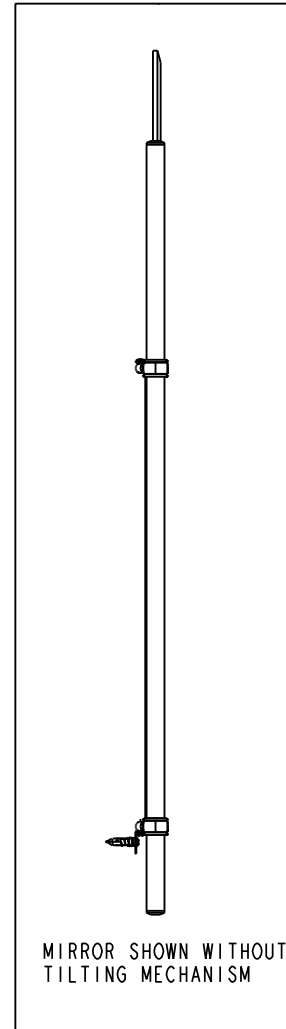
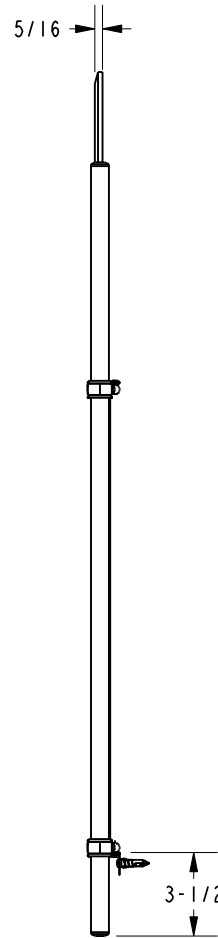
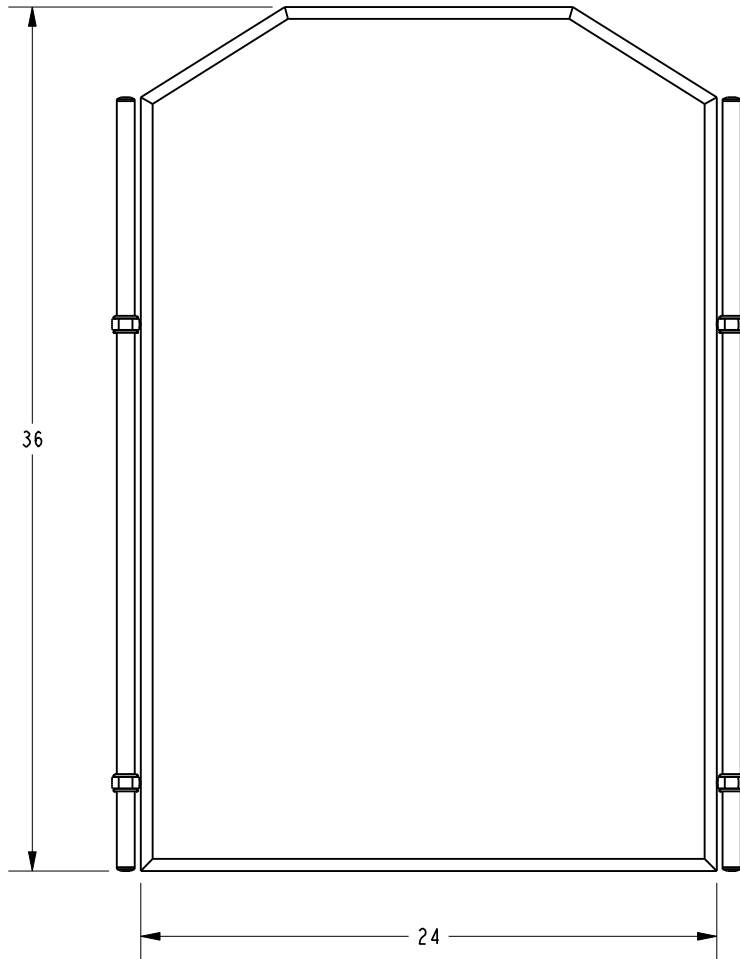
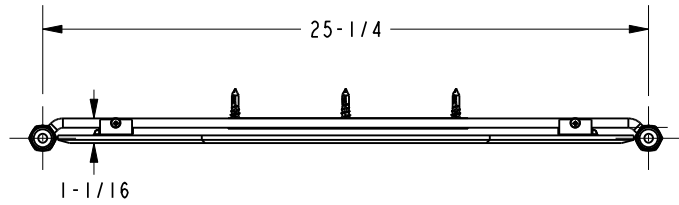

DIMENSIONS ARE IN INCHES AND AN APPROXIMATION OF A TYPICAL INSTALLATION

COPYRIGHT 2005 GINGER. THESE DRAWINGS AND THE DESIGNS DEPICTED HEREIN ARE THE PROPRIETARY PROPERTY OF GINGER. ANY USE OR REPRODUCTION IS SUBJECT TO THE EXPRESS APPROVAL OF GINGER. UNAUTHORIZED USE IS STRICTLY PROHIBITED. ALL RIGHTS RESERVED.

GINGER		2001 CARNEGIE AVE. SANTA ANA CA 92705 (949) 417-5207	
DWG NO.	642	REV	B
SCALE	.125	REF.	SHEET 3 OF 3