

Plan
14922010000 Towel ring

PRODUCT

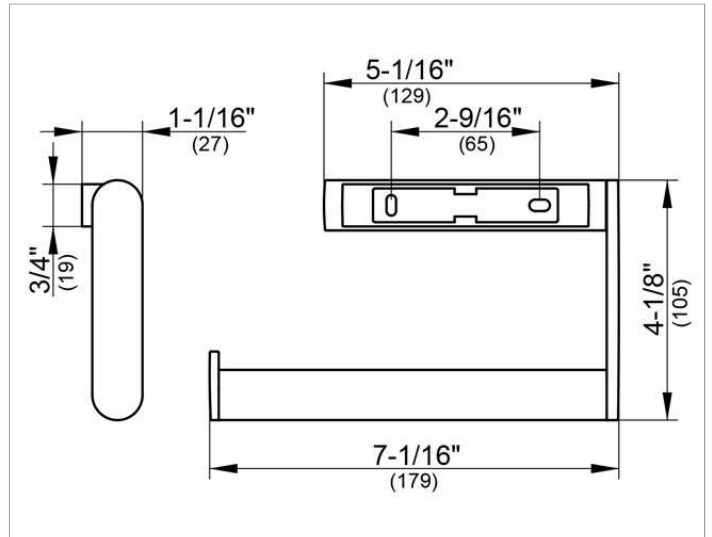

DRAWING



PRODUCT ATTRIBUTES

small model

SURFACE

polished chrome

SPECIFICATIONS

KEUCO PLAN towel ring 14922010000
 Chrome-plated towel ring in a stylish yet functional design
 Small model, open form, rectangular
 Towel arm swivels, load bearing up to 55 lb, anti static, easy to clean
 Width 7-1/16", height 4-1/8"
 The towel ring is fitted with 2 hidden fixing points
 incl. corrosion-free mounting material

Warranty: KEUCO products are covered by a 5-year manufacturer's warranty, in effect from the date of purchase. During this time, proven product defects will be remedied free of charge. Warranty claims must be filed in writing, including a detailed description of the defect immediately after a defect has occurred. For a copy of our detailed product warranty policy, please contact us at office-usa@keuco.com.

Installation: KEUCO products must be installed by a qualified professional in accordance with the respective installation guidelines and any applicable federal / local building codes and regulations.