

Kraus Undermount Stainless Steel Sink Installation Instructions

For the Attention of the Customer and the Installer:

1. For best results, Kraus recommends that the solid surface countertop cut-out should only be prepared by a professional fabricator, and undermount sinks should only be installed by a professional installer.
2. The enclosed paper template represents Kraus recommended countertop cut-out specification and sink mounting style.
3. Sink installation and countertop cut-out choices are not limited to Kraus specifications. Installer and customer must discuss these options, and reach an agreement on alternate countertop cut-out dimensions and sink installation methods prior to preparation of the countertop. Kraus will not be held responsible for alternate choices of sink installation and countertop cut-out.
4. In addition to the Kraus paper template, electronic (.dxf) files for countertop cut-outs are available on the Kraus website www.kraususa.com
5. Sink mounting requirements will vary according to countertop selection. Hardware for mounting the sink to the countertop is not included, and should be specified by the countertop fabricator for the specific countertop selection.
6. Sink may have sharp edges, please use caution when handling.
7. Inspect the sink unit prior to installation to confirm acceptance. Do not install a damaged unit.
8. Kraus USA is not responsible for any damage to sink or countertop incurred during installation.
9. Please follow all local plumbing and building codes.

KRAUS CUSTOMER SERVICE

Toll-free: 1.800.775.0703

Phone: 1.646.461.9199

Email: customerservice@kraususa.com

Hours: 9:00am to 8:00pm (EST) Monday thru Friday

Please note Kraus recommended sink mounting specifications A and B:

KRAUS RECOMMENDED

SPECIFICATION A: 1/4" REVEAL

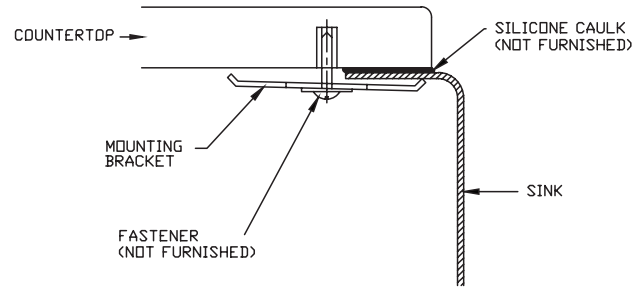
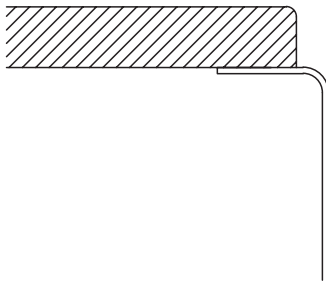

KRAUS RECOMMENDED

SPECIFICATION B: 1/8" OVERHANG

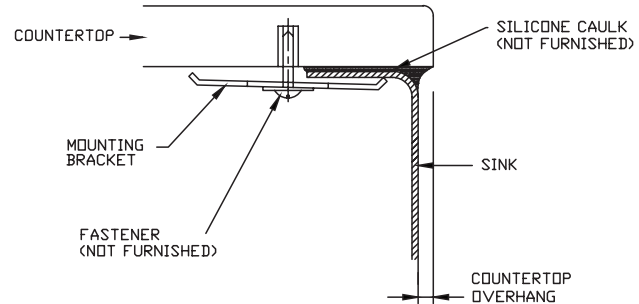
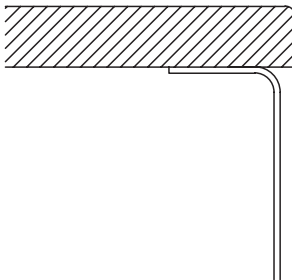

OPTIONAL CHOICE AT DISCRETION OF CUSTOMER

FLUSH FIT INSTALLATION

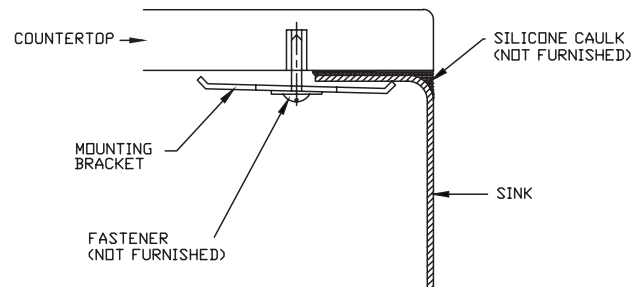
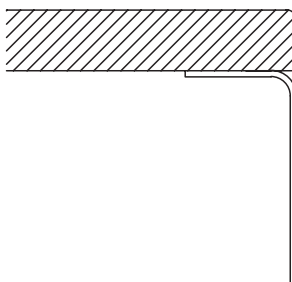

Flush fit installation is **NOT** recommended by Kraus.
Exposure of silicone joint is not considered aesthetically acceptable.
Precise match of sink and countertop cut-out is extremely difficult.

The following instructions apply only to Kraus-recommended sink mounting specification A and B.

1. Position undermount sink template on countertop, centered within the sink base cabinet unit. Make sure to provide adequate clearance from the countertop backsplash, with room for mounting faucet and fittings behind the sink. Avoid any potential interference with cabinet bracing.
2. Countertop cut-out may be prepared by using either the paper template included within the sink carton, or referencing the .dxf file found on www.kraususa.com
 - 2A. Trace a line around the paper template. Cut along the inside of this line to create opening in countertop.
 - 2B. Select the dxf file for the Kraus model purchased. CNC machine the countertop cut-out based on this dxf file.
3. Locate and drill the sink fastener mounting holes (following the countertop manufacturer's instructions). Type of fasteners should be recommended by countertop supplier.
4. Loosely fasten sink mounting clips to countertop.
5. Apply a bead of silicone caulking (not included) evenly along the sink flange.
6. Position and align sink to the countertop. Tighten fasteners until sink mounting clips are snug against the sink flange.
7. Check alignment of sink to cut-out opening, and adjust if necessary. Tighten fasteners evenly. DO NOT overtighten.
8. Wipe up and remove any excess silicone from the countertop cut-out edge.

Kraus Recommended Optional Accessories

NOTE: Kraus recommends using a high-quality dish grid with your stainless steel sink to protect the bottom of the basin from wear and tear. To ensure the proper fit, we recommend the following matching grids:

	DEX™ SERIES STAINLESS STEEL SINK	MODEL NO.	RECOMMENDED DISH GRID	MODEL NO.
1.	17" Undermount Single Bowl Stainless Steel Bar Sink	KD1US17B	15" Stainless Steel Kitchen Sink Grid	BG1517
2.	25" Undermount Single Bowl Stainless Steel Kitchen Sink	KD1US25B	23" Stainless Steel Kitchen Sink Grid	BG2317
3.	33" Undermount Single Bowl Stainless Steel Kitchen Sink	KD1US33B	31" Stainless Steel Kitchen Sink Grid	BG3117
4.	33" Undermount Double Bowl Stainless Steel Kitchen Sink	KD1UD33B	15" Stainless Steel Kitchen Sink Grid	BG1517 (x) 2

KRAUS CUSTOMER SERVICE

Toll-free: 1.800.775.0703

Phone: 1.646.461.9199

Email: customerservice@kraususa.com

Hours: 9:00am to 8:00pm (EST) Monday thru Friday



Kräus[®]

INSTALLATION MANUAL

Single Handle Pull-Down Kitchen Faucet

KPF-1673

Thank you for your purchase

We would like to take this opportunity to thank you for choosing Kraus. We hope that you are completely satisfied with your purchase, and enjoy it for years to come. If you have any questions, or require technical assistance, please contact us at 800.775.0703 and one of our representatives will be happy to help.

For more information about Kraus products, please visit:

www.kraususa.com

In order to activate your warranty and get faster access to customer support, please register your new Kraus product at:

www.kraususa.com/registration

Sincerely,

Kraus USA Customer Service

Prior to Installation:

- Make sure you have all necessary parts by checking the diagram and parts list. If any part is missing or damaged, please contact Kraus Customer Service at 800-775-0703 for a replacement
- Turn off the cold and hot water at the angle stops and turn on the old faucet to release any built up pressure
- Flush angle stops to release any debris prior to installation
- Pre-drilled hole size requirement: 1-3/8" (min) – 1-1/2" (max)
- Max countertop thickness: 1-3/8
- 1, 2, or 3 hole installation

For technical assistance or replacement parts, please contact Kraus Customer Service and one of our representatives will be happy to help:

Toll-Free: 800-775-0703 or Customerservice@kraususa.com

Diagram and Parts List

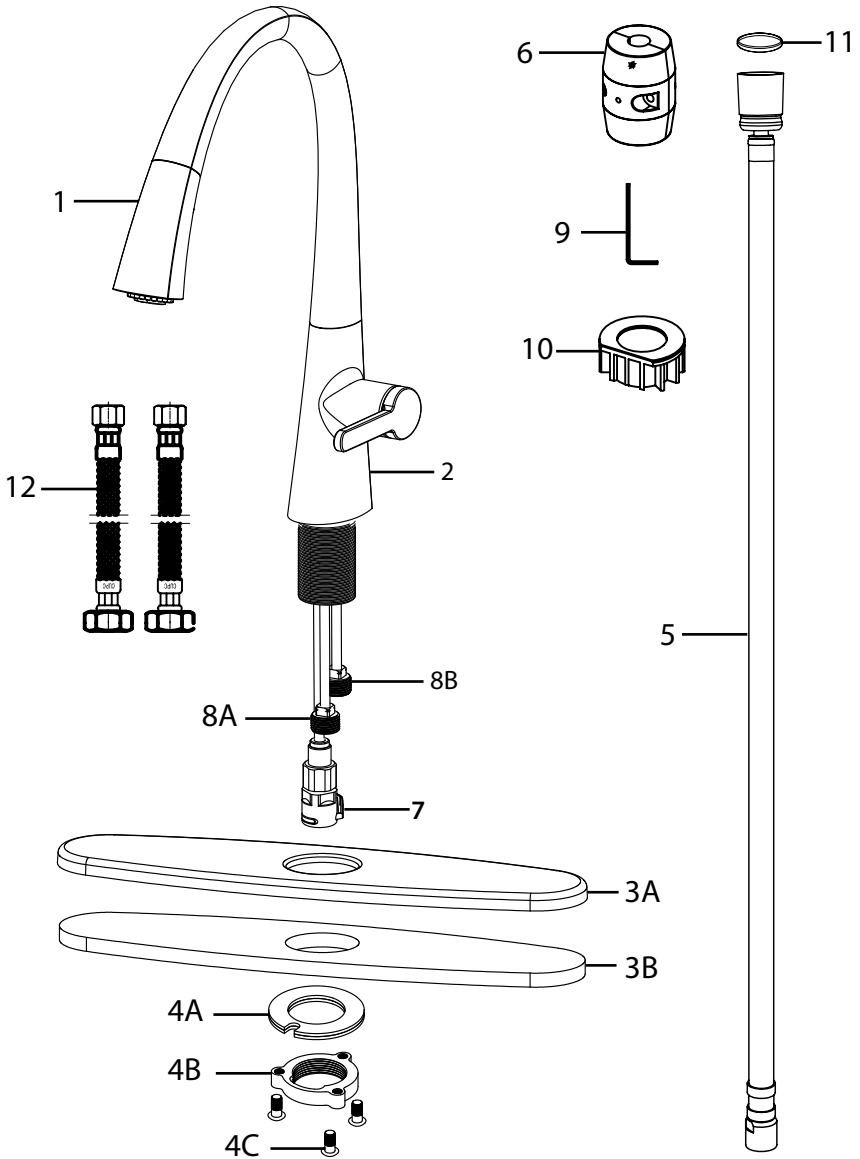

Diagram and Parts List

1. Spray Head
2. Faucet Body
3. Deck Plate Assembly
 - A. Deck Plate
 - B. Base Plate
4. Mounting Hardware
 - A. Rubber & Metal Washer
 - B. Mounting Nut
 - C. Mounting Screws
5. Spray Hose
6. Weight
7. Quick Connector
8. Hot and Cold Copper Lines
 - A. Cold
 - B. Hot
9. Hex Wrench
10. Faucet Extender
11. Washer
12. Hot & Cold Waterlines

Tools you will need



Adjustable Wrench

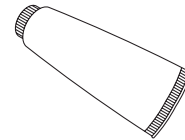

Silicone Sealant
(optional)

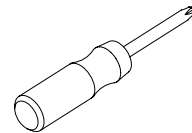

Phillips Screwdriver



Safety Goggles

Faucet Installation Procedure

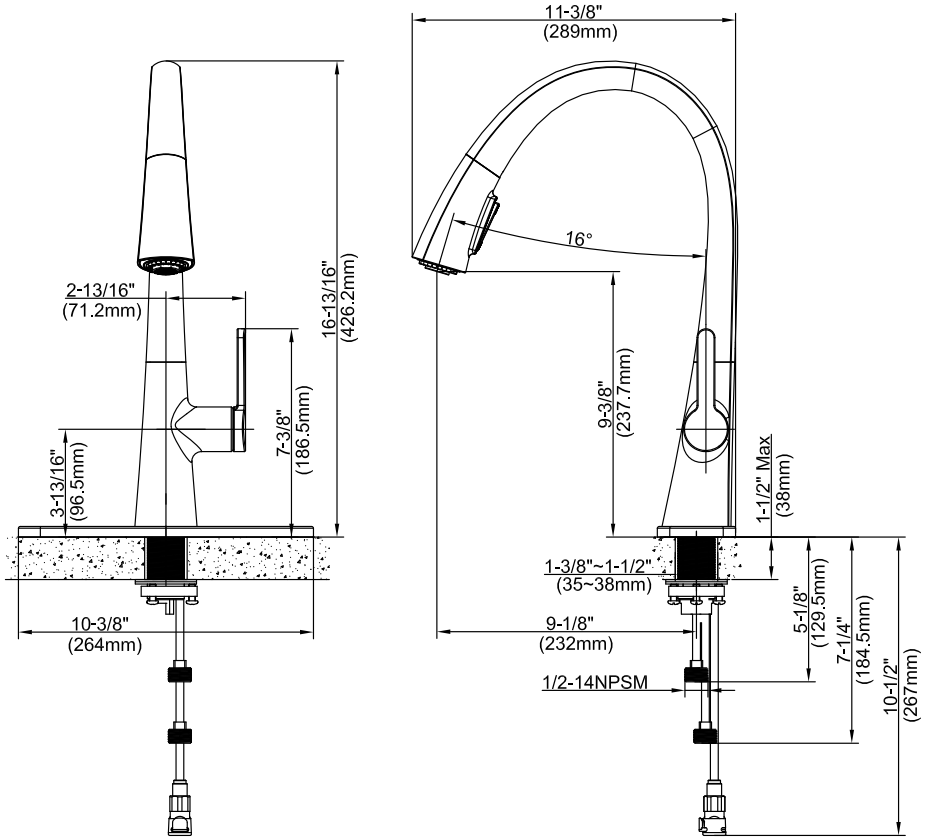

Installer Tip:

Shut off main water supply before installing new faucet

Step 1: Remove mounting hardware

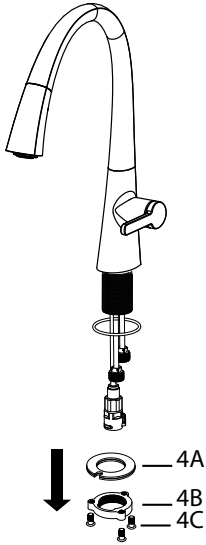

Remove the mounting screws (4C), mounting nut (4B), and rubber & metal washer (4A) from the mounting pipe

Step 2A: Faucet installation - with deck plate

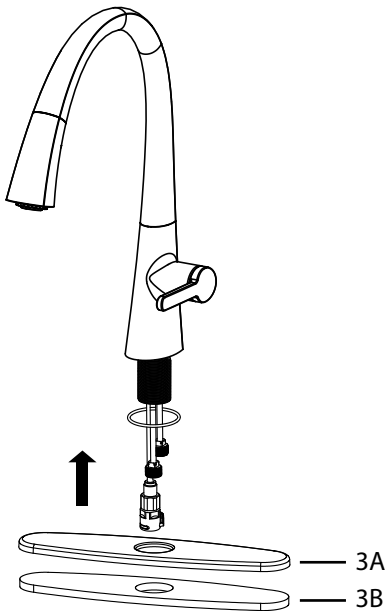

For three-hole installation: Deck plate (3A), base plate (3B), and silicone sealant (optional) are required

Step 2B: Faucet installation - without deck plate

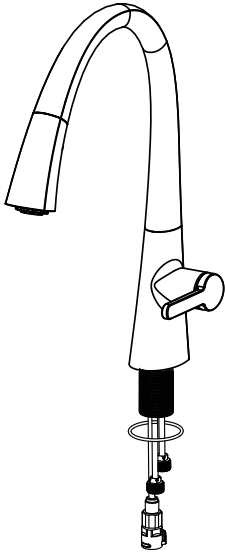

For single-hole installation:
Deck plate (3A), base plate
(3B), and silicone sealant
are **NOT** required

Step 3: Install faucet and mounting hardware

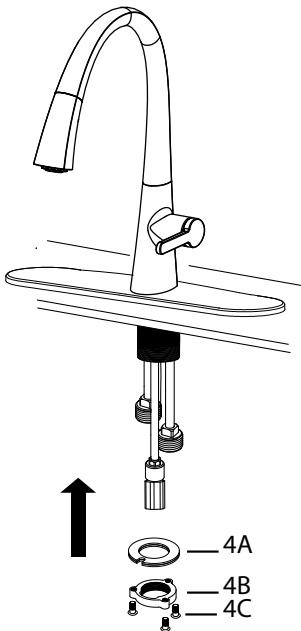

Insert faucet body (2) into
hole in countertop or deck
plate assembly (3). Install
mounting hardware (4A, B
& C) from underneath the
countertop

Step 4: Secure mounting hardware

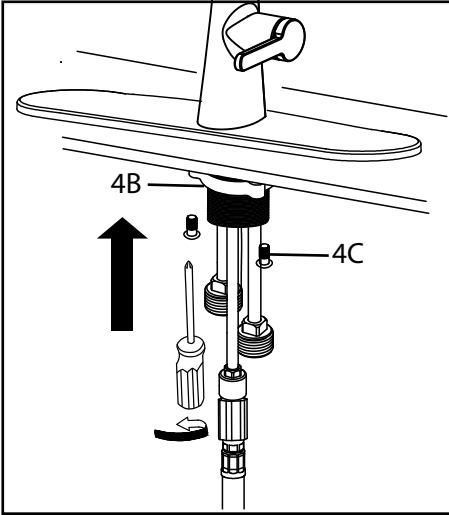

Adjust direction of faucet body (2) so that handle is on right side of faucet. Tighten mounting nut (4B) until snug. Tighten mounting screws (4C) to nut with Phillips screwdriver until snug

Step 5: Attach spray hose and counterweight

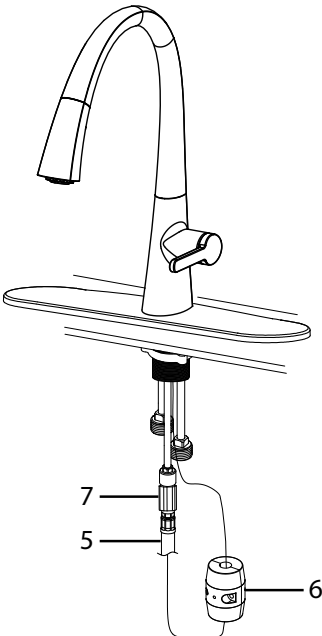

Connect spray hose (5) to quick connector (7) attached to supply line. Install weight (6) on lowest vertical point on spray hose (5)

Step 6: Connect waterlines

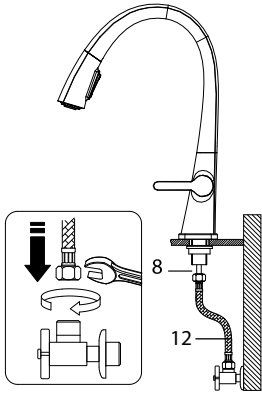

Connect waterlines (not included) to hot and cold copper lines (8). Connect waterlines (12) to angle stops. Tighten both ends of waterlines with a wrench until snug. Turn on hot and cold angle stops and check for leaks

Step 7: Flush spray hose

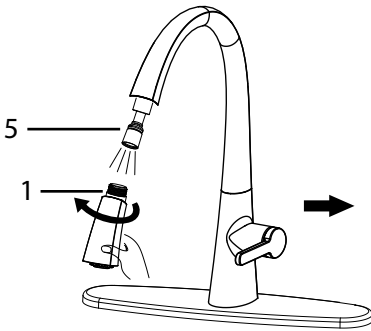

Remove spray head (1) from spray hose (5). Hold tip of spray hose (5). Turn faucet on and let the water run for 60 seconds to flush any debris

NOTE: Please make sure washer (11) is installed attaching spray head to hose

Step 8: Check for leaks

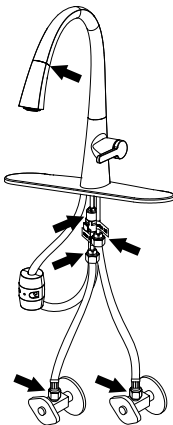

Check for leaks at the connections. Retighten if necessary

Replacement Parts

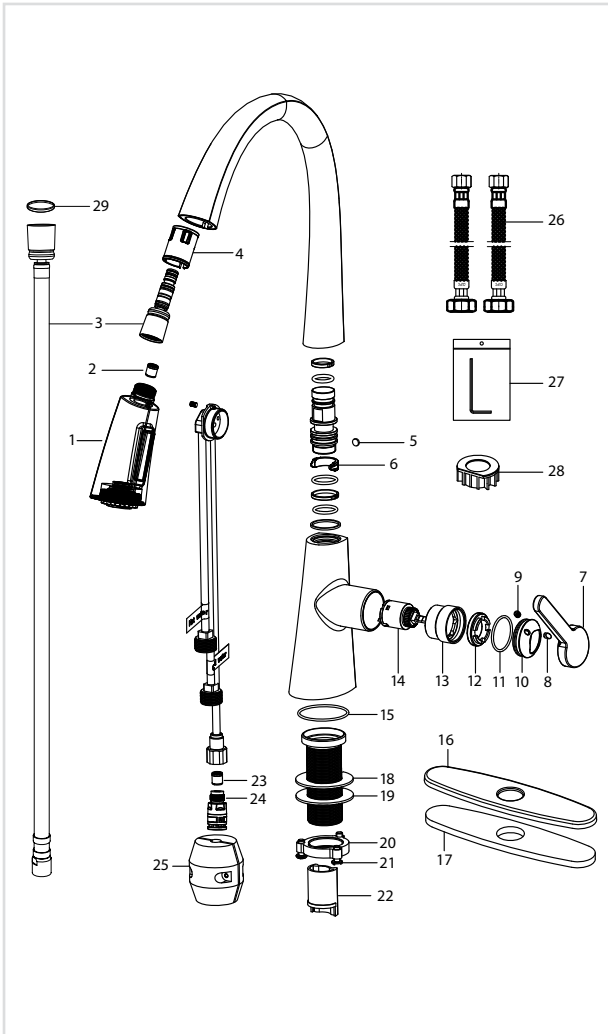

1. Spray Head
2. Check Valve
3. Spray Hose
4. Hose Guide
5. Button
6. Plastic Clip
7. Metal Handle
8. Handle Button
9. Set Screw
10. Cartridge Cover
11. O-Ring
12. Locking Nut
13. Cartridge Housing
14. Cartridge
15. Rubber O-Ring
16. Deck Plate
17. Base Plate
18. Rubber Washer
19. Metal Washer
20. Mounting Nut
21. Mounting Screws
22. Protective Sleeve
23. Check Valve
24. Quick Connector
25. Weight
26. Hot & Cold Waterlines
27. Hex Wrench
28. Faucet Extender
29. Washer

Care & Maintenance

*To keep the product clean & shining, follow the steps below:

1. Rinse with clean water & dry with a soft cloth
2. Do not clean with soaps, acid, polish, abrasives, or harsh cleaners
3. Do not use cloth with a coarse surface
4. Unscrew the aerator and clean when necessary

*This installation manual is subject to change without further notice.



Trouble - Shooting

If you have followed the instructions carefully and your faucet still does not work properly, take the following corrective steps:

PROBLEM	CAUSE	ACTION
Leakage under faucet handle	Locking nut has come loose or cartridge needs to be reseated	Remove button located at top of handle. Loosen set screw with hex wrench. Remove handle and unscrew cartridge cover by hand. Tighten locking nut with an adjustable wrench
Water does not shut off completely	Cartridge may need to be adjusted or replaced	Remove button located at top of handle. Loosen set screw with hex wrench. Remove handle and unscrew cartridge cover by hand. Unscrew locking nut with an adjustable wrench. Remove ceramic disc cartridge. Check for cracks, and if O-ring is seated correctly. Reseat cartridge
Leaking between spray head and the hose	Spray head may be loose or washer is not seated correctly in the hose connection	Tighten spray head by hand until snug. Make sure washer is seated correctly
Hose does not retract	Weight may be installed incorrectly	Readjust weight on hose
Low flow	Aerator may be clogged	Unscrew aerator with aerator key. Hold tip of spray head and turn on water to flush debris

Maintenance - Cartridge Replacement



Step 1: Remove button located at the top of the cartridge cover. Loosen the set screw with a hex wrench. Remove the handle and unscrew cartridge cover by hand



Step 2: Unscrew the locking nut with an adjustable wrench. Remove ceramic disc cartridge



Step 3: Place the new cartridge in the handle seat. Secure the cartridge with the locking nut and assemble the handle

Codes / Standards Applicable:



NSF/ANSI Standard 61 certified by IAPMO
NSF/ANSI Standard 372 certified by IAPMO



Meets ASME A112.18.1M/A112.18.1
1.75GPM 6.6L/min maximum

FAUCET WARRANTY

Kraus products are manufactured and tested to the highest quality standards by Kraus USA Inc. ("Kraus"). Kraus extends this warranty to the original purchaser for personal household use of the "Faucet" in its original location. The warranty is non-transferable.

Kraus warrants the structure and finish of the product to be free from defects in material and workmanship under normal usage for the lifetime of the product. The warranty commences from the initial date of purchase by the owner or trade professional, from an authorized Kraus dealer, through the lifetime of the original owner or end-user.

Kraus warrants the mechanical component (**sprayhead assembly**) of the product to be free from defects in material and workmanship under normal usage for a period of one (1) year. The warranty commences from the initial date of purchase by the owner or trade professional, from an authorized Kraus dealer, through the one (1) year term of the original owner or end-user.

Kraus warrants the mechanical component (**cartridge**) of the product to be free from defects in material and workmanship under normal usage for a period of five (5) years. The warranty commences from the initial date of purchase by the owner or trade professional, from an authorized Kraus dealer, through the five (5) year term of the original owner or end-user.

Any product reported to the authorized dealer or to Kraus as being defective within the warranty period will be repaired or replaced with a product of equal value at the option of Kraus. This warranty extends to the original owner or end-user, and is not transferable to a subsequent owner.

RESTRICTIONS

This warranty does not cover antediluvian, discontinued, or display products, whether such items are purchased at discount outlets, unauthorized dealers, and/or sold on clearance. This warranty does not cover instances of negligence, misuse, abuse, improper installation, carelessness, accident, hard water or mineral deposits, exposure to corrosive materials, misapplication, damages caused by improper maintenance, alteration of the product, or failure to follow care or installation instructions enclosed with your product. Avoid using abrasive cleaners such as powders, bleach, ammonia, alcohol, or chlorine. Avoid using abrasive pads, steel wool, or wire brushes, as these will damage and wear down the finish. This warranty does not apply to Products that have not been installed or operated in accordance with instructions supplied by Kraus and all applicable rules, regulations, and legislation pertaining to such installations.

This warranty does not apply unless the Kraus product is installed by a fully insured and licensed trade professional. Kraus insists that such professionals have experience in the installation of bathroom and kitchen manufactured goods.

This warranty does not cover labor charges or costs of removal and reinstallation of said product. This warranty does not allow recovery of incidental or consequential damages, such as loss of use, delay, property damage, or other consequential damages, and Kraus accepts no liability for such damages.

This warranty does not cover Marine or Outdoor Installation.

Except as otherwise provided above, Kraus makes no warranties, expressed or implied, including warranties of merchantability and fitness for a particular purpose, or compliance with any code. Shipping charges will be covered for the first (1) year of the warranted replacement part or product (HI, AK, and Puerto Rico shipping charges may apply). International shipping fees are not included.

COMMERCIAL WARRANTY

Kraus extends the above warranty for a period of one (1) year to purchasers of products for industrial, commercial, and business use.

All incidental or consequential damages are specifically excluded. No additional warranties, express or implied, are given, including but not limited to any implied warranty of merchantability or fitness for a particular purpose.

Some states do not allow the exclusion or limitation of incidental or consequential damages or limitations on how long an implied warranty lasts, so the above limitations or exclusions may not apply to you.

This warranty gives you specific legal rights, and you may also have other rights which vary from state to state.

If you are a homeowner please contact a Kraus Customer Service Representative at:

Kraus USA, Inc.
12 Harbor Park Drive
Port Washington, NY 11050
Toll-free 800-775-0703
Customerservice@kraususa.com

If you are a plumbing contractor or trade professional please contact a Kraus Pro Representative at:

Kraus USA, Inc.
12 Harbor Park Drive
Port Washington, NY 11050
516-801-8955
Proservice@kraususa.com

If you are an Authorized Partner please contact a Partner Support Representative at:

Kraus USA, Inc.
12 Harbor Park Drive
Port Washington, NY 11050
516-801-8954
Partnersupport@kraususa.com

In requesting warranty service, please be ready to provide:

1. Proof of purchase.
2. A description of the problem.

Download the Kraus Care & Maintenance Guide at:

<http://www.kraususa.com/maintenance>

REGISTER YOUR PRODUCT TODAY

Receive Proof of Ownership
Access Customer Care & Installation Help
Get Exclusive Kraus Offers & Promotions



Scan to Register Online
or visit <http://www.kraususa.com/registration>

We're always looking for ways to improve.

Please take a moment to share your experience.
Visit <http://www.kraususa.com/review> to let us know what you think
about your new Kraus product.

Contact Us to Learn More
1.800.775.0703 / www.kraususa.com / customerservice@kraususa.com
Like & Follow KrausUSA

Download the Kraus Care & Maintenance Guide at:
<http://www.kraususa.com/maintenance>



Kräus[®]

www.kraususa.com

