

NOTE(S):
 1. PART NUMBER, "/00" DENOTES PART SHALL HAVE FINISH.

2. APPLY NSF COMPLIANT GREASE TO ANY O-RING, SEALING JOINTS, AND/OR PIVOTAL POINTS.

3. APPLY NSF COMPLIANT LOCTITE TO THREADED AREA.

4. APPLY NSF COMPLIANT REMOVABLE (BLUE) LOCTITE TO THREADED AREA.

5. SILVER SOLDER JOINTS SHALL BE FULLY WETTED VIA CAPILLARY ACTION AND COMPLETELY NON-POROUS.

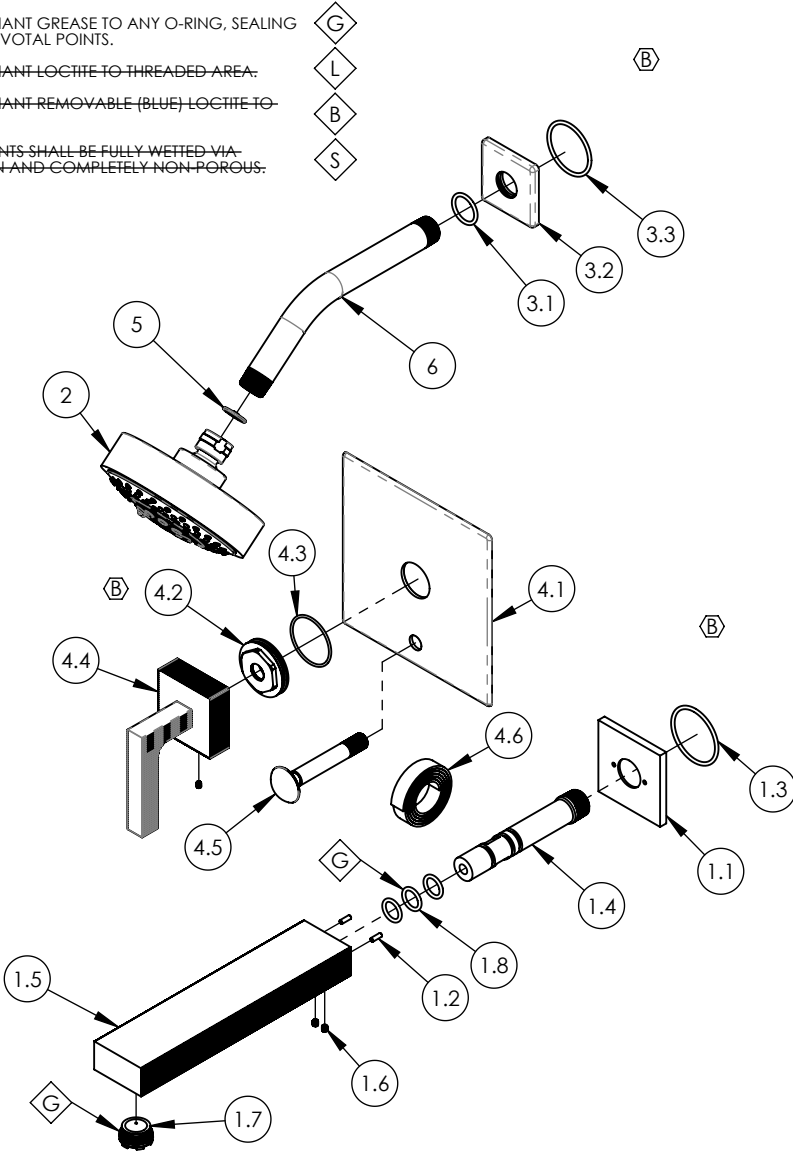

ITEM NO.	PART NUMBER	DESCRIPTION	QTY.
1	3-127/00	SPOUT, WALL TUB, 291 STRIA	1
1.1	10939/00	ESCUTCHEON, WIDESPREAD	1
1.2	92158	DOWEL PIN, 1/8" X 3/8" L	2
1.3	90131	O-RING, 1-11/16ID X 3/32THK, AS-568-131	1
1.4	10013	INJECTOR SHANK, 1/2"NPT MALE TO M16.5 CACHE W/ O-SEAL	1
1.5	11010/00	SPOUT, WALL MOUNT	1
1.6	92008	SET SCREW, CUP POINT 8-32, 3/16" L.	2
1.7	P05051	AERATOR, CACHE COINED SLOT M24X1.0 FULL FLOW	1
1.8	90113	O-RING, 9/16"ID X 3/4"OD X 3/32"THK, AS-568-113	3
2	3-454/00	SHOWER HEAD MULTI. FUNC. CONTEMP.	1
3	3-719/00	SHOWER FLANGE, MIX/ STRIA	1
3.1	90117	O-RING, 7/8"ID X 33/32"THK., AS-568-117	1
3.2	10935/00	ESCUTCHEON, SHOWER FLANGE MIX SERIES	1
3.3	90129	O-RING, 1-9/16"ID X 3/32THK, AS-568-129	1
4	4-120/00	PB PLATE W/ DIVERTER, LEVER HANDLE, STRIA	1
4.1	10959/00	SHOWER TRIM PLATE W/ DIVERTER HOLE, MIX SERIES	1
4.2	92401	BASE MOUNT, TRIM PLATE TO ESCUTCHEON	1
4.3	90029	O-RING, 1-5/8"ID X 1-3/4"OD X 1/16"THK, AS-568-029	1
4.4	3-129/00	PB SHOWER SET, LEVER EDGE SERIES	1
4.5	3-125/00	DIVERTER EXTENSION ASSY FOR PB TUB & SHOWER SET	1
4.6	90537	1/16" TAPE FOR WALL PLATE	1
5	11432	1.75 GPM FLOW REGULATOR	1
6	P16008/00	SHOWER ARM (8 INCH)	1

C3, C5, E3	B	EXPLODE VIEW, UPDATE SHOWER ASSY, TRIM PLATE ASSY, & SPOUT ASSY	6/11/2021	AMM
ZONE	REV.	DESCRIPTION	DATE	APPROVED

REVISIONS

1261 LOGAN AVENUE
 COSTA MESA, CALIFORNIA 92626
 PHONE: 714.361.4800
 FAX: 714.617.3120

PHYLIRICH[®]
 Defining Luxury Since 1959

PROPRIETARY AND CONFIDENTIAL
 THE INFORMATION CONTAINED IN THIS DRAWING IS THE SOLE PROPERTY OF PHYLIRICH. ANY REPRODUCTION IN PART OR AS A WHOLE WITHOUT THE WRITTEN PERMISSION OF PHYLIRICH IS PROHIBITED.
DO NOT SCALE DRAWING

PB SHOWER W/ DIVERTER SET TRIM, LEVER HANDLE, STRIA

SIZE A	ASM/PRT NO. 291-27/00	REV B
SCALE: 1:5.5	WEIGHT: lbs.	SHEET 1 OF 2

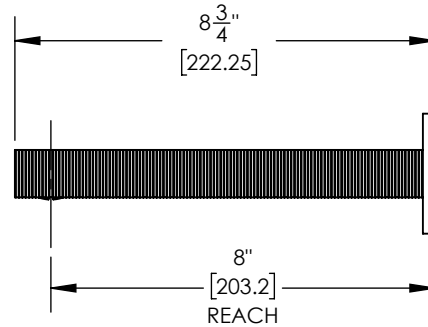
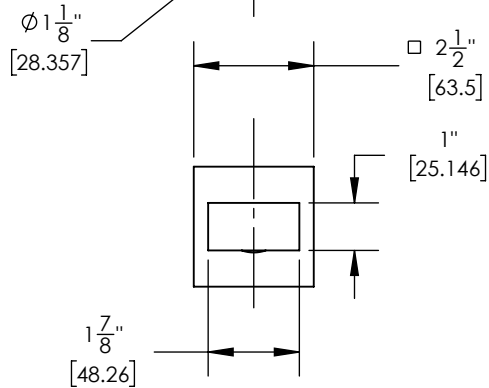
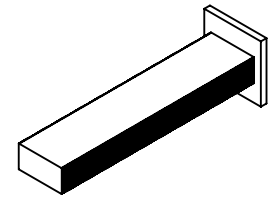
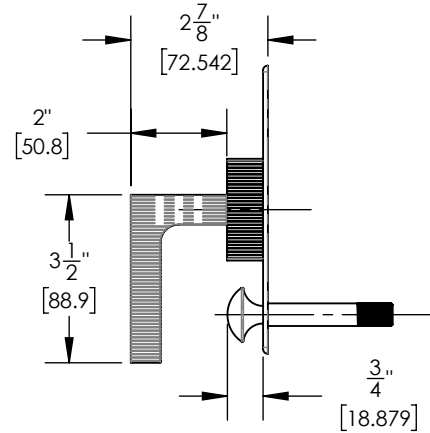
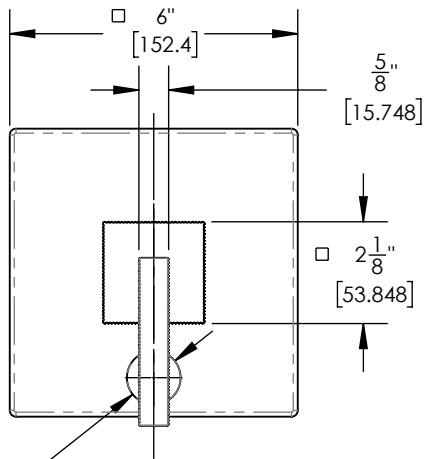
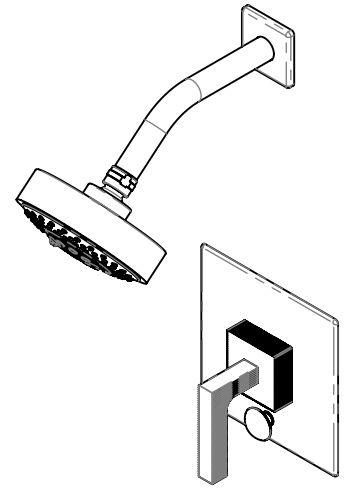
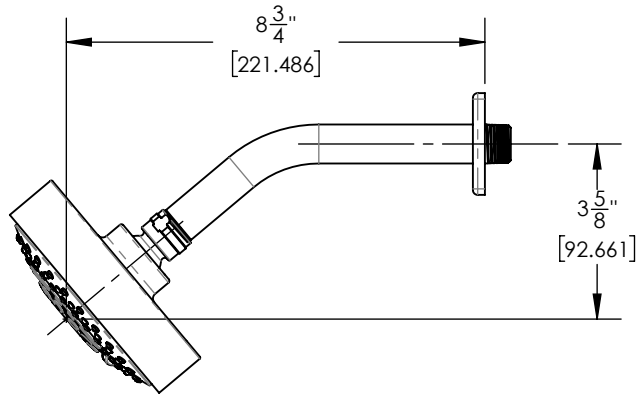
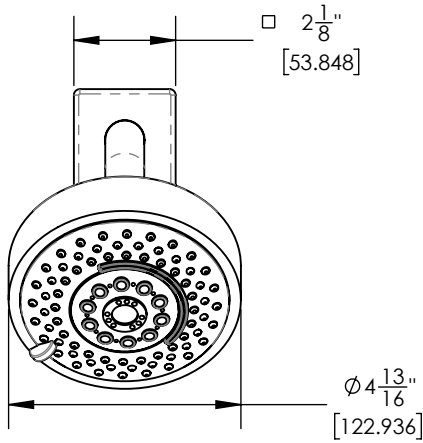

1261 LOGAN AVENUE
 COSTA MESA, CALIFORNIA 92626
 PHONE: 714.361.4800
 FAX: 714.617.3120

PHYLIRICH[®]
 Defining Luxury Since 1959

PROPRIETARY AND CONFIDENTIAL
 THE INFORMATION CONTAINED IN THIS DRAWING IS THE SOLE PROPERTY OF PHYLIRICH. ANY REPRODUCTION IN PART OR AS A WHOLE WITHOUT THE WRITTEN PERMISSION OF PHYLIRICH IS PROHIBITED.
DO NOT SCALE DRAWING

PB SHOWER W/ DIVERTER SET TRIM, LEVER HANDLE, STRIA

SIZE A	ASM/PRT NO. 291-27/00	REV B
SCALE: 1:4	WEIGHT: lbs.	SHEET 2 OF 2