

NOTE(S):  
 1. APPLY NSF COMPLIANT GREASE TO ANY O-RING, SEALING JOINTS, AND/OR PIVOTAL POINTS.  
 2. APPLY NSF COMPLIANT LOCTITE TO THREADED AREA.

\*DONT FORGET CARTRIDGE O-RING

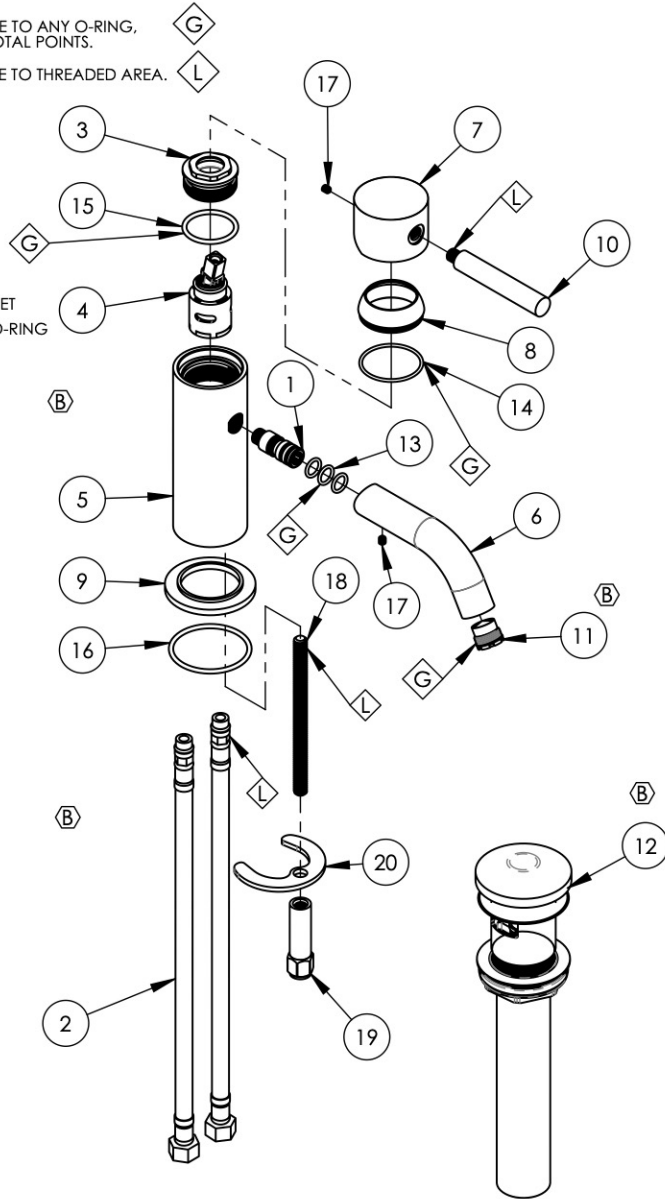

ITEM NO.	PART NUMBER	DESCRIPTION	QTY.
1	10230	INJECTOR, FRONT SINGLE CONTROL SEAL SUPPORT	1
2	10665	HOSE, CONNECTOR, M8.1 x 3/8", 17" LG.	2
3	10869	NUT, CARTRIDGE, SINGLE LEVER	1
4	10985	STSR CARTRIDGE ST231, 25MM OPEN	1
5	11088/00	BODY, CONTEMPORARY BASIC II LAV	1
6	11089/00	SPOUT, SHORT 60 BEND CONTEMPORARY BASIC II	1
7	11091/00	HUB HANDLE, SINGLE CTRL CONTEMP. BASIC II	1
8	11092/00	CAP, CONTEMP. BASIC II LAV	1
9	11093/00	ESCUTCHEON BASE, CONTEMP. BASIC II	1
10	11094/00	HANDLE LEVER, CONTEMPORARY SINGLE CTRL LAV BASIC II	1
11	11430	AERATOR, CACHE TOM THUMB, PINK 1.2 GPM, M16.5X1.0, NEOPERL # 44.3260.450	1
12	3-545/00	BRASS PUSH TYPE DRAIN, W/ OVERFLOW & SMALL PLUG	1
13	90012	O-RING, 3/8"ID X 1/2"OD X 1/16"THK, AS-568-012	3
14	90028	O-RING, 1-3/8"ID X 1/16"THK, AS-568-028	1
15	90122	O-RING, 1-1/8" ID X 3/32"THK. AS-568-122	1
16	90132	O-RING, 1-3/4"ID X 3/32THK, AS-568-132	1
17	92008	SET SCREW, CUP POINT 8-32, 3/16" L.	2
18	92064	ROD, MOUNTING 5/16"-18 X 4.5"L	1
19	92065	MOUNTING NUT, 5/16"-18 X 2"L	1
20	92066	WASHER, HORSESHOE .328 HOLE	1

ALL	B	UPDATE TEMPLATE/AERATOR, REMOVE POP UP KNOB/ DRAIN, ADD NOTES	4/1/2020	AMM
ZONE	REV.	DESCRIPTION	DATE	APPROVED
REVISIONS				

1261 LOGAN AVENUE  
 COSTA MESA, CALIFORNIA 92626  
 PHONE: 714.361.4800  
 FAX: 714.617.3120

**PHYLIRICH**<sup>®</sup>  
 Defining Luxury Since 1959

**PROPRIETARY AND CONFIDENTIAL**  
 THE INFORMATION CONTAINED IN THIS DRAWING IS THE SOLE PROPERTY OF PHYLIRICH. ANY REPRODUCTION IN PART OR AS A WHOLE WITHOUT THE WRITTEN PERMISSION OF PHYLIRICH IS PROHIBITED.

-	-	INTERPRET GEOMETRIC DIMENSIONING & TOLERANCING IN ACCORDANCE WITH ASME Y14.5-2009 & ASME Y14.41-2003 STANDARDS, UNLESS OTHERWISE SPECIFIED. DIMENSIONS ARE IN INCHES. TOLERANCES ARE:		
NEXT ASSY	USED ON	FRACTIONS ±1/16"	DECIMALS X.X: ±.1 X.XX: ±.01 X.XXX: ±.005	ANGULAR ±2°
APPLICATION		MATERIAL	NAME	DATE
FINISH		DRAWN	LLO	3/13/2015
DO NOT SCALE DRAWING		CHECKED	GRE	

**SINGLE CONTROL LAV., LEVER HANDLE, BASIC II**

SIZE **A** ASM/PRT NO. **230-09/00** REV **B**

SCALE: 1:4.5 WEIGHT: lbs. SHEET 1 OF 2