

NOTE(S):
 1. PART NUMBER, "/00" DENOTES PART SHALL HAVE FINISH.

2. APPLY NSF COMPLIANT GREASE TO ANY O-RING, SEALING JOINTS, AND/OR PIVOTAL POINTS.

3. APPLY NSF COMPLIANT LOCTITE TO THREADED AREA.

4. APPLY NSF COMPLIANT REMOVABLE (BLUE) LOCTITE TO THREADED AREA.

5. SILVER SOLDER JOINTS SHALL BE FULLY WETTED VIA CAPILLARY ACTION AND COMPLETELY NON-POROUS.



ITEM NO.	PART NUMBER	DESCRIPTION	QTY.
1	2-376/00	GRAB BAR, 18" C-C, BRAZE	1
2	30399/00	ESCUTCHEON, GRAB BARS	2
3	30400/00	SPUD, GRAB BARS	2
4	92043	SCREW, FLAT HD #10 SIZE W/ #2 PHIL DRIVE, 2"L	6
5	92046	ANCHOR SCREW 3/8" HOLE, TOGGLER AF10	6
6	92367	MOUNTING BRACKET, GRAB BAR	2

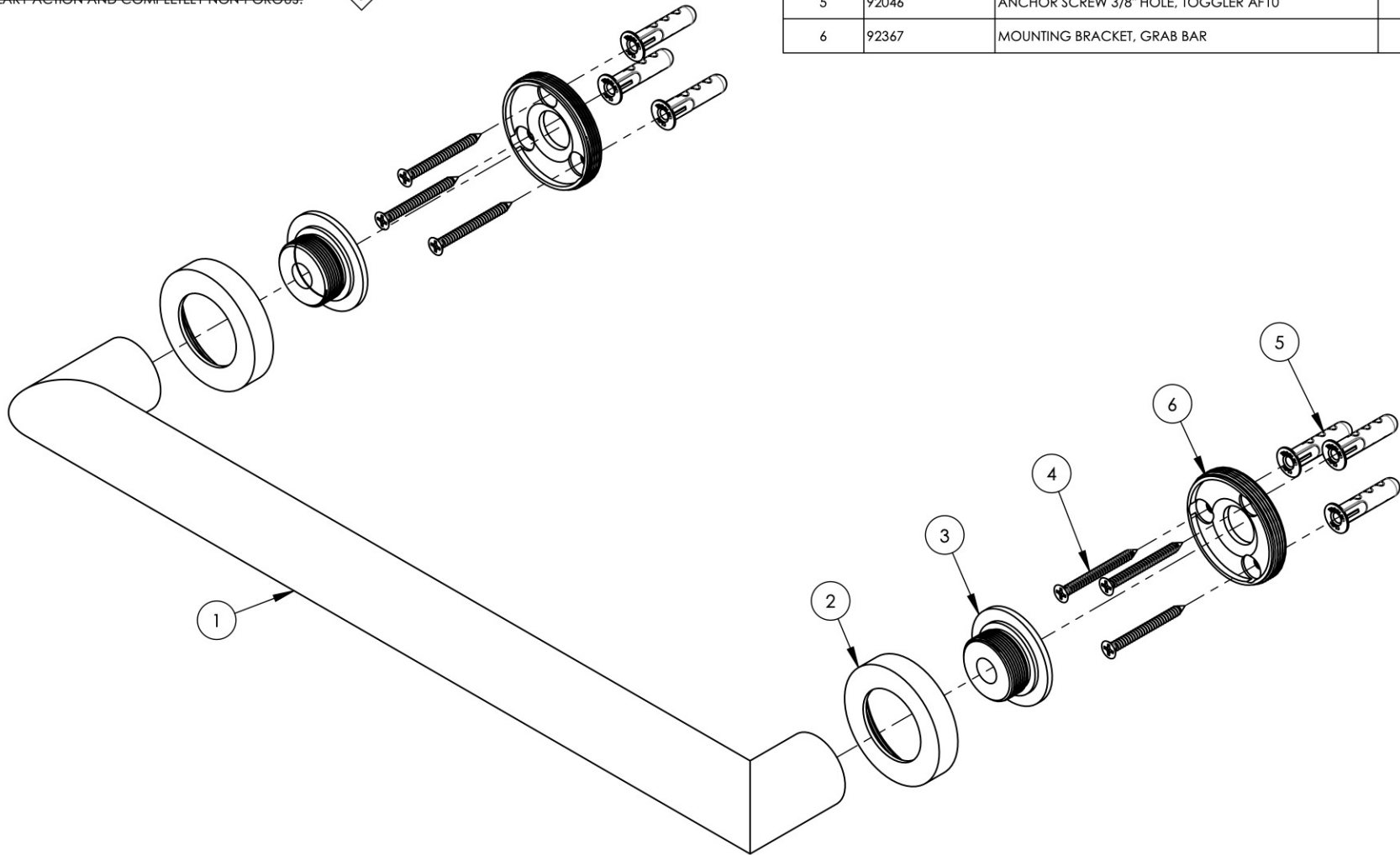

ZONE	REV.	DESCRIPTION	DATE	APPROVED
REVISIONS				

1261 LOGAN AVENUE
 COSTA MESA, CALIFORNIA 92626
 PHONE: 714.361.4800
 FAX: 714.617.3120

PHYL RICH[®]
 Defining Luxury Since 1959

PROPRIETARY AND CONFIDENTIAL
 THE INFORMATION CONTAINED IN THIS DRAWING IS THE SOLE PROPERTY OF PHYL RICH. ANY REPRODUCTION IN PART OR AS A WHOLE WITHOUT THE WRITTEN PERMISSION OF PHYL RICH IS PROHIBITED.
DO NOT SCALE DRAWING

GRAB BAR 18", TRANSITION

SIZE **A** ASM/PRT NO. 120-86/00 REV -

SCALE: 1:3 WEIGHT: lbs. SHEET 1 OF 2